

EDA and Quantum Computing: The Role of Circuits

—
Dr. Leon Stok
VP – EDA
IBM



The Future of Computing: Bits + Neurons + Qubits



Bits

Mathematics + Information

Today's Computers and
Supercomputers

Neurons

Biology + Information

Today's AI Systems

Qubits

Physics + Information

Today's Quantum Systems

Accelerated Discovery



Bits + Neurons + Qubits

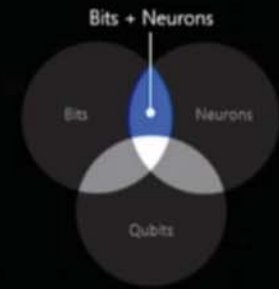
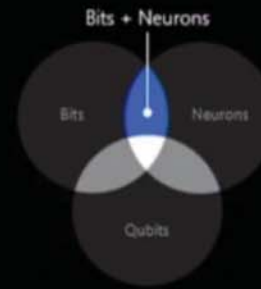
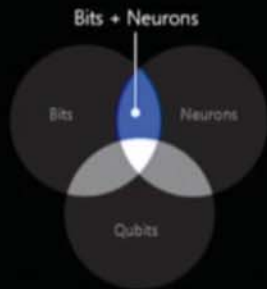

Deep Search

Intelligent Simulation

Generative Models

Autonomous Labs

Why quantum?

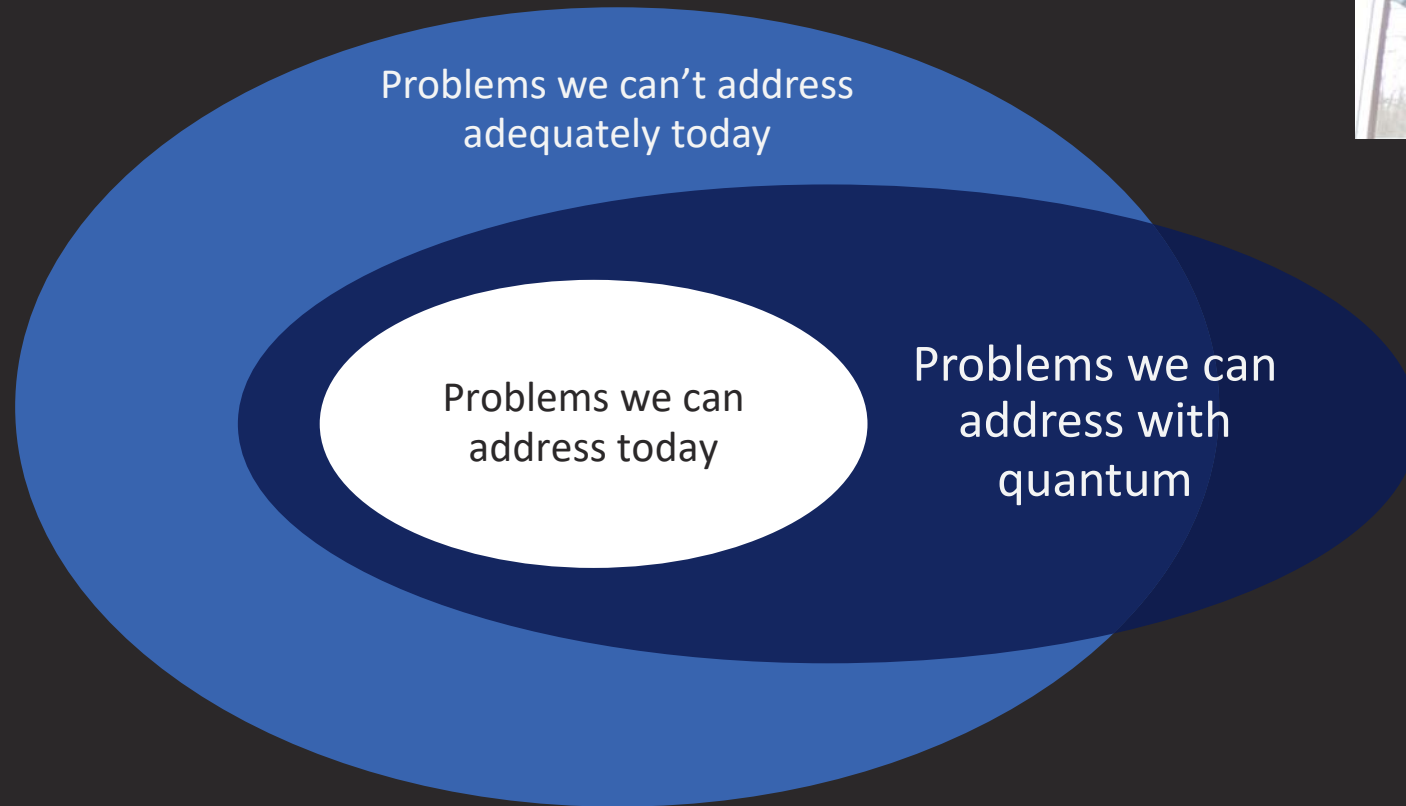

Despite how sophisticated digital computing has become, there are many scientific and business problems for which we've barely scratched the surface.

Are quantum computers “faster”?



$$p * q = N$$

How long does it take to
multiply 2048 bit
integers ?

Classical Cost of
multiplication [1]:
~ 0.0025s

Quantum Cost of
multiplication [2]:
~ 75.0000s

[1]: A. Emerencia, "Multiplying huge integers using fourier transforms." (2007).

[2]: C. Gidney, Craig, and M. Ekerå. arXiv preprint arXiv:1905.09749 (2019).

Are quantum computers “faster”?



$$N = p * q$$

How long does it take to
factor 2048 bit integers ?

Classical Cost of
factoring [1]:

~ 4.7 billion CPU years

(largest factored number RSA-
768 bit for approx. 1500 CPU
years)

[1]: Kleinjung, Thorsten, et al. "Factorization of a
768-bit RSA modulus." Annual Cryptology
Conference. Springer, Berlin, Heidelberg, 2010.

Quantum Cost of
factoring [2]:

~ 8 hours

[2]: C. Gidney, Craig, and M. Ekerå. arXiv preprint
arXiv:1905.09749 (2019).



Improved nitrogen-fixation process for creating ammonia-based fertilizer



New catalysts to make CO₂ conversion into hydrocarbons more efficient and selective



Better financial models to improve stability, predictability and growth of world economies

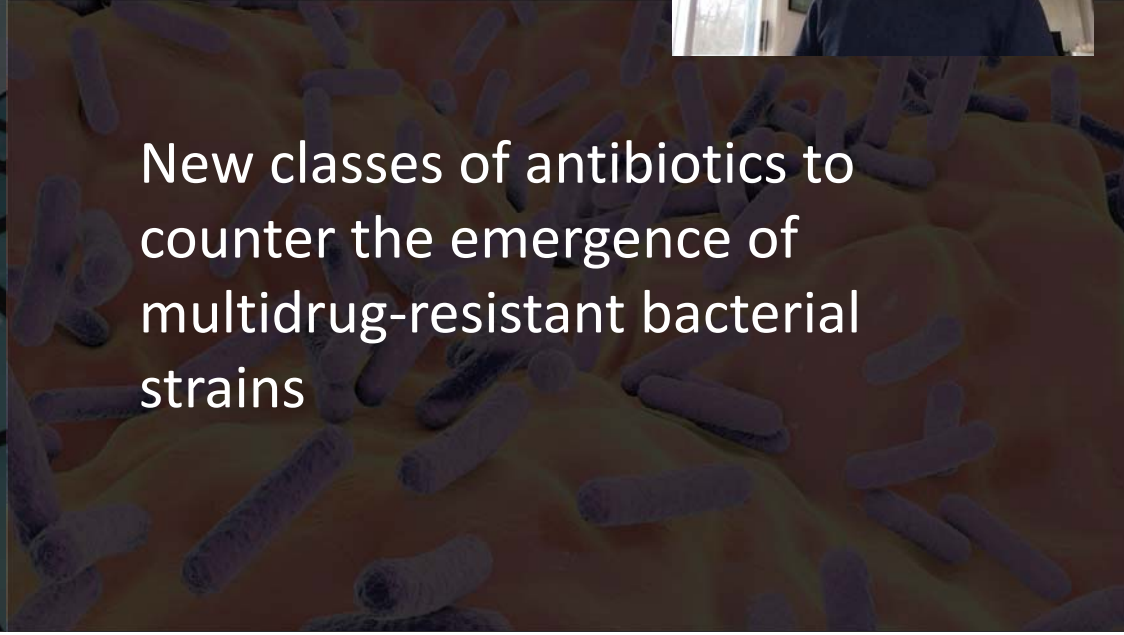

New classes of antibiotics to counter the emergence of multidrug-resistant bacterial strains



Quantum volume

Many factors contribute to the performance of the overall system

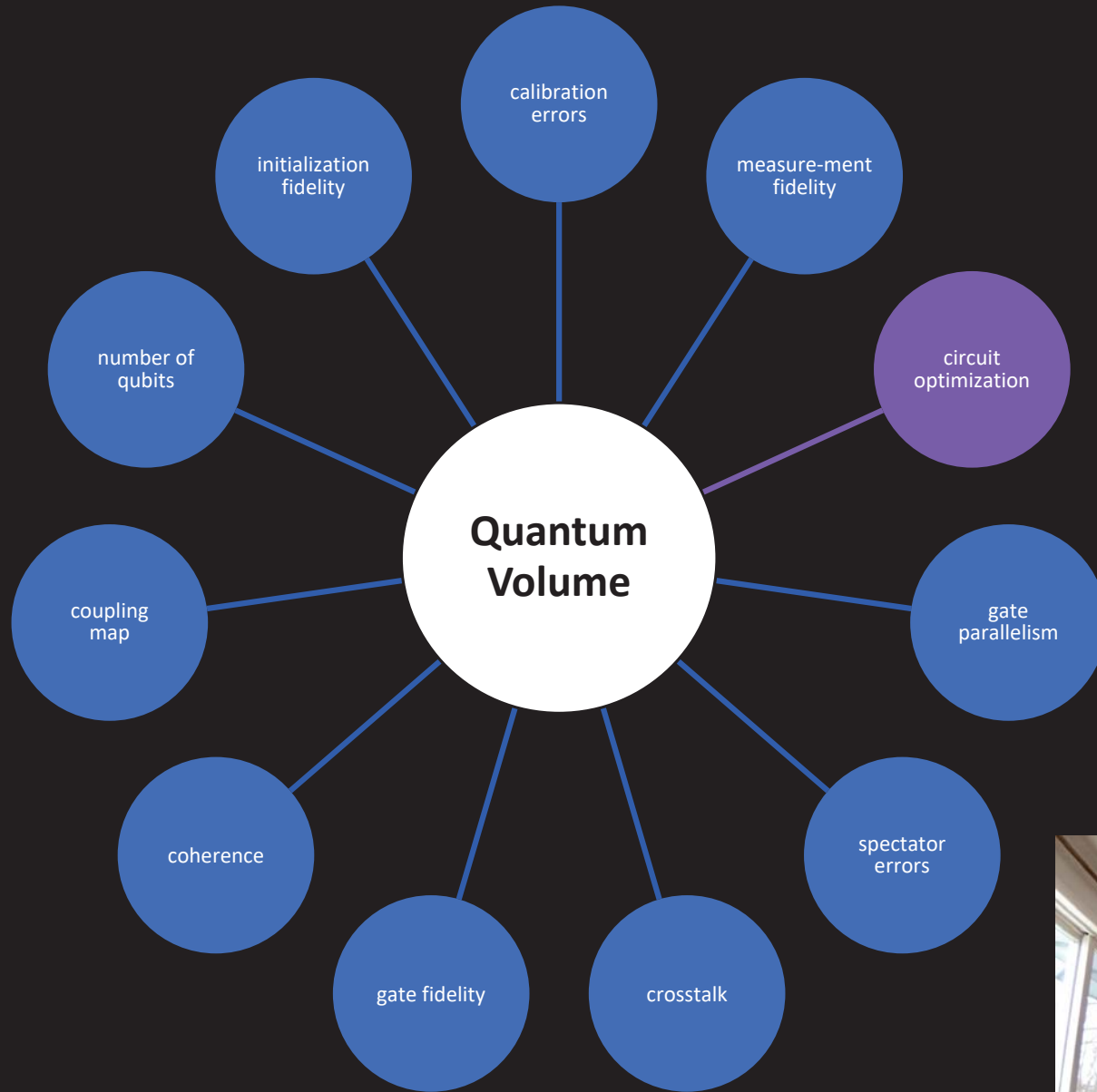
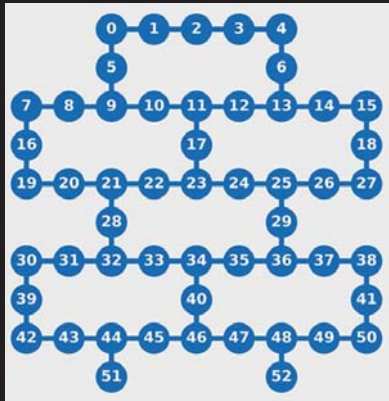

We are in the early stages of a rapidly advancing new computing technology



Moore's law

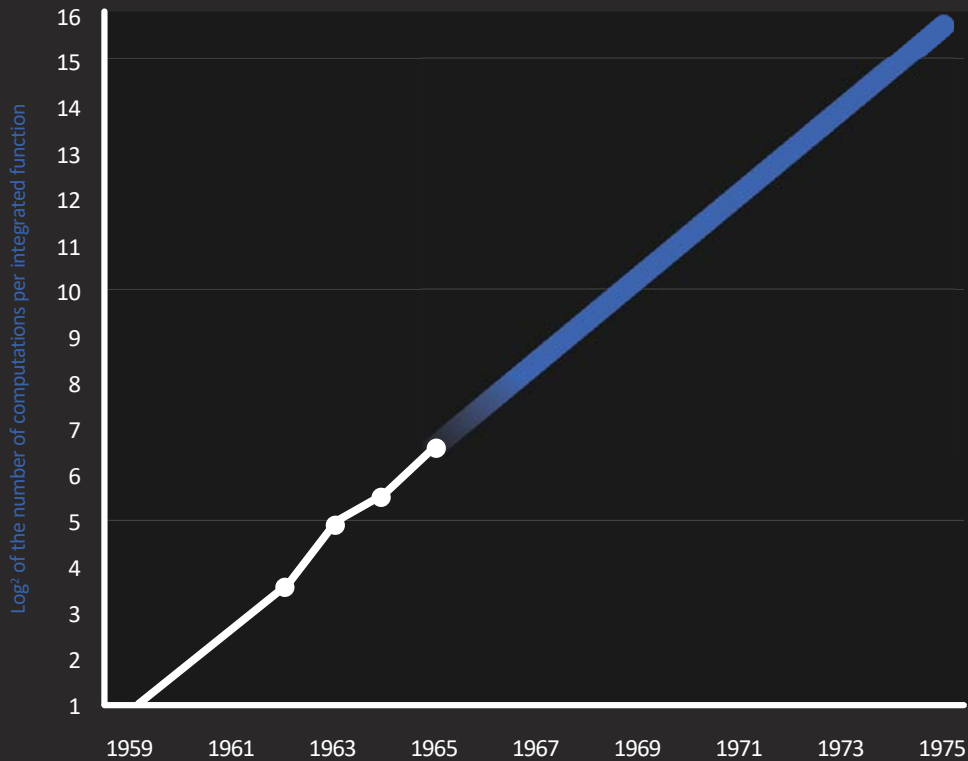

Quantum Volume: The New Moore's Law

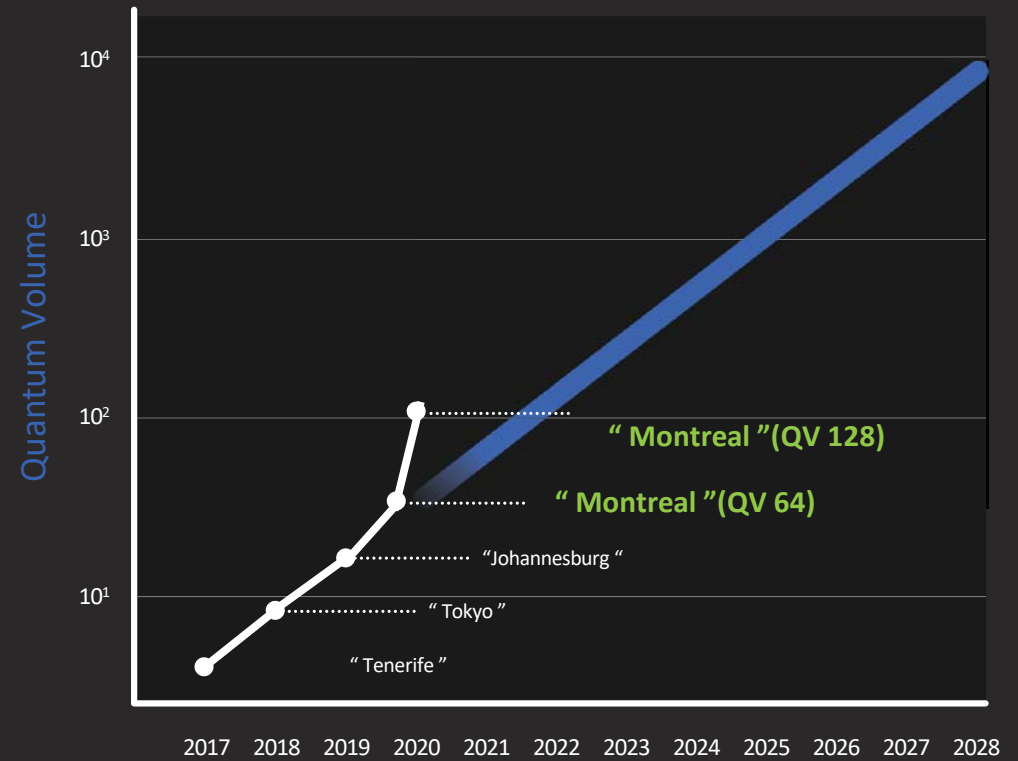

Inside an IBM Quantum Chip



[Design and Test of Quantum Computers, ITC2019](#)

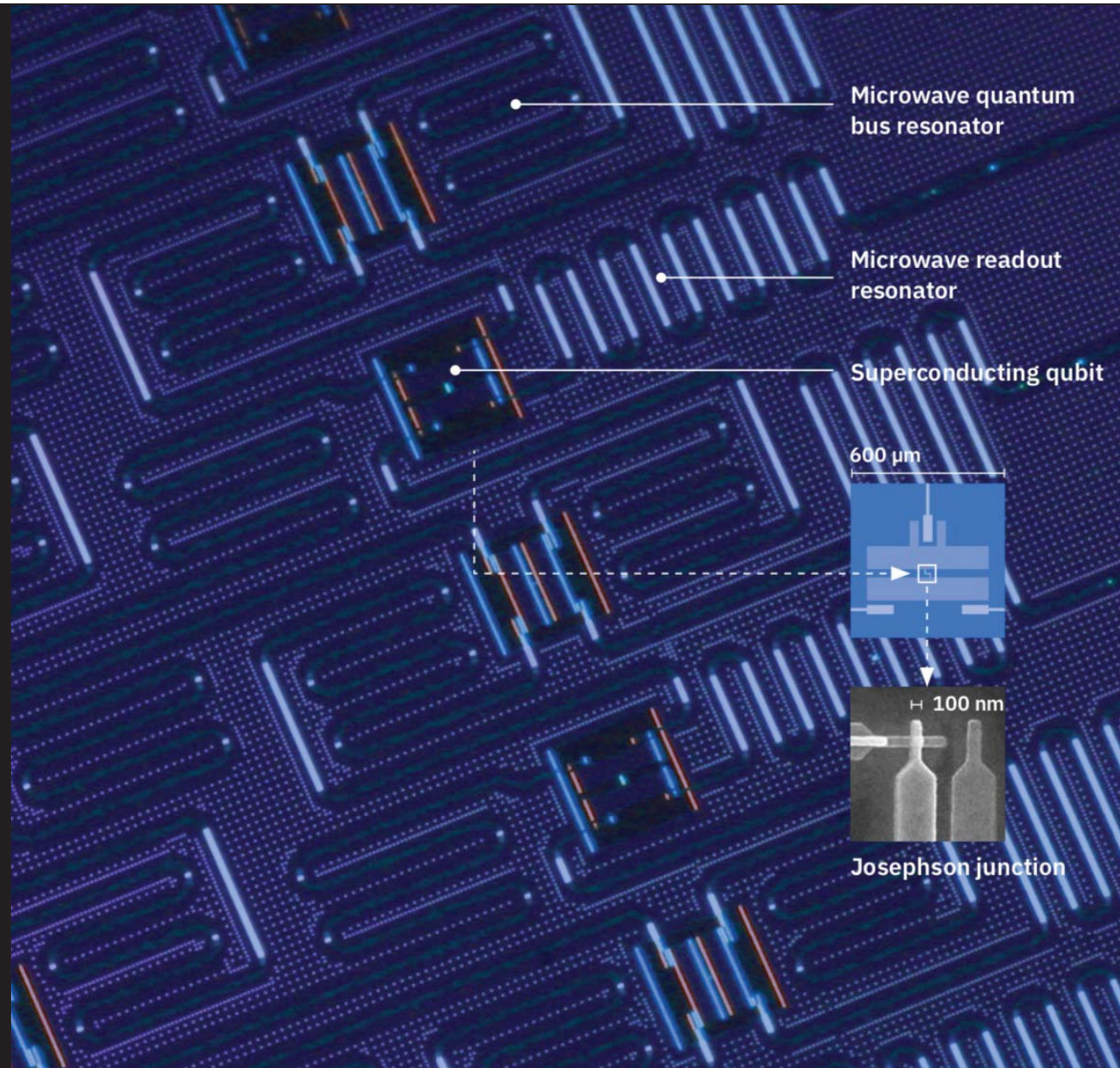

Scaling IBM Quantum technology

IBM Quantum

IBM Quantum System One (Released)

(In development)

Next family of IBM Quantum systems

2019

2020

2021

2022

2023

and beyond

27 qubits

65 qubits

127 qubits

433 qubits

1,121 qubits

Path to 1 million qubits

Falcon

Hummingbird

Eagle

Osprey

Condor

and beyond

Large scale systems

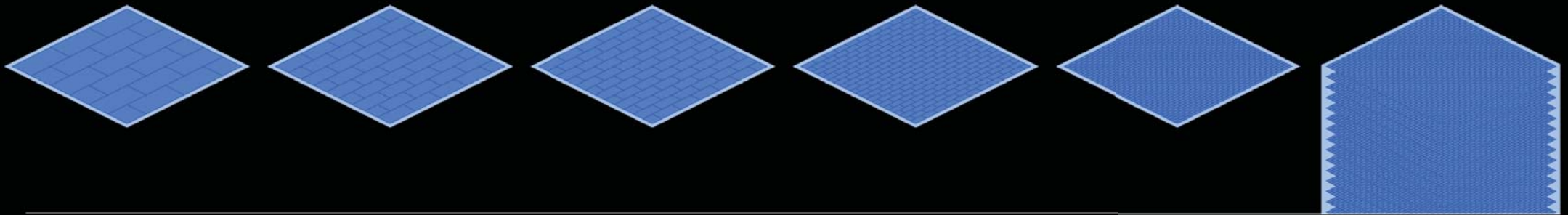

Key advancement

Key advancement

Key advancement

Key advancement

Key advancement

Optimized lattice

Scalable readout

Novel packaging and controls

Miniaturization of components

Integration



Superfridge - first of its kind dilution refrigerator 10 x the cooling power at 100 mK and 8 x the cooling planned at 4K



Development Roadmap

2019 2020 2021 2022 2023 2024 2025 2026+

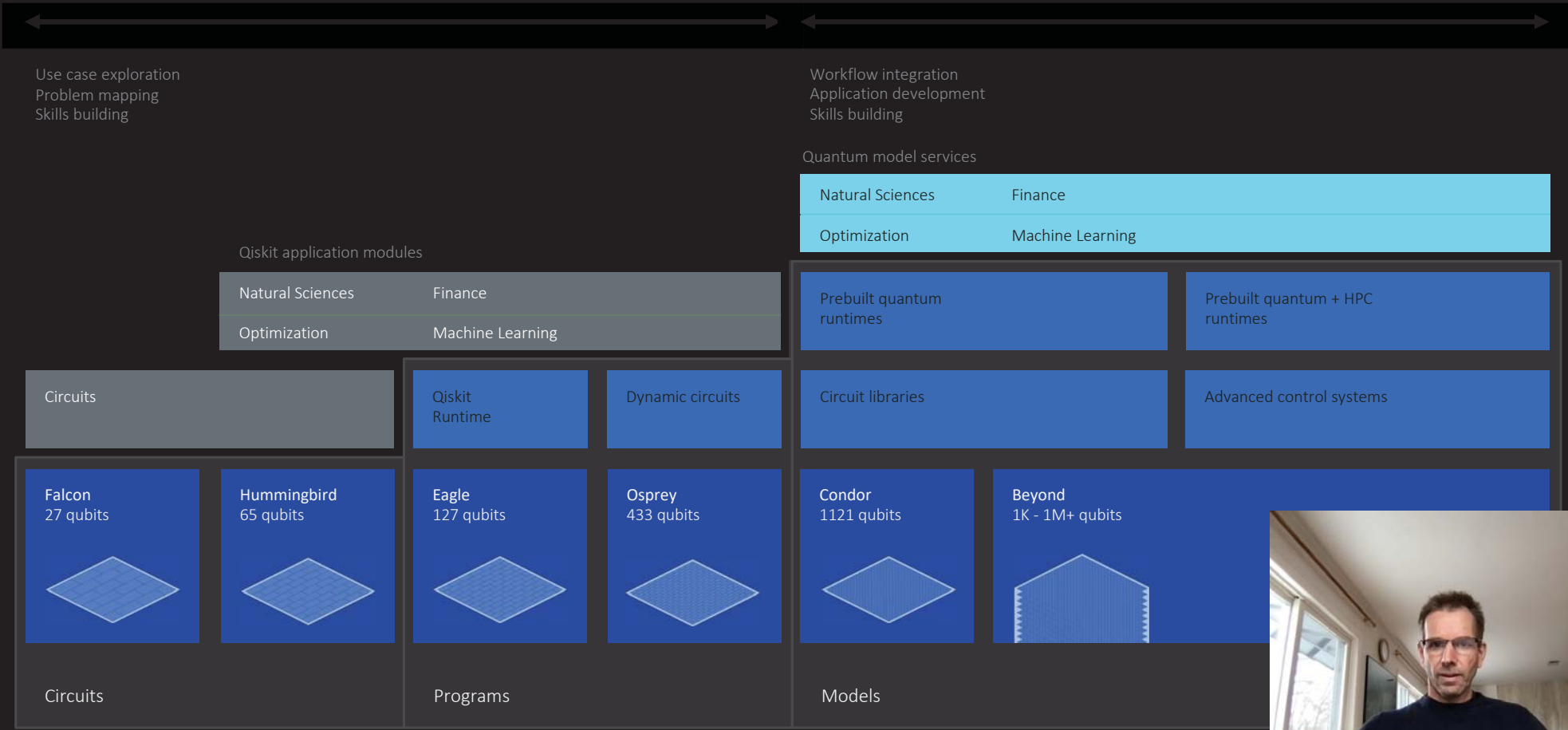

Development Roadmap

2019 2020 2021 2022 2023 2024 2025 2026+

Kernel developers

Circuits

Qiskit Runtime

Dynamic circuits

Circuit libraries

Advanced control systems

Quantum systems

Falcon
27 qubits

Hummingbird
65 qubits

Eagle
127 qubits

Osprey
433 qubits

Condor
1121 qubits

Beyond
1K - 1M+ qubits

IBM Cloud

Circuits

Programs

Models



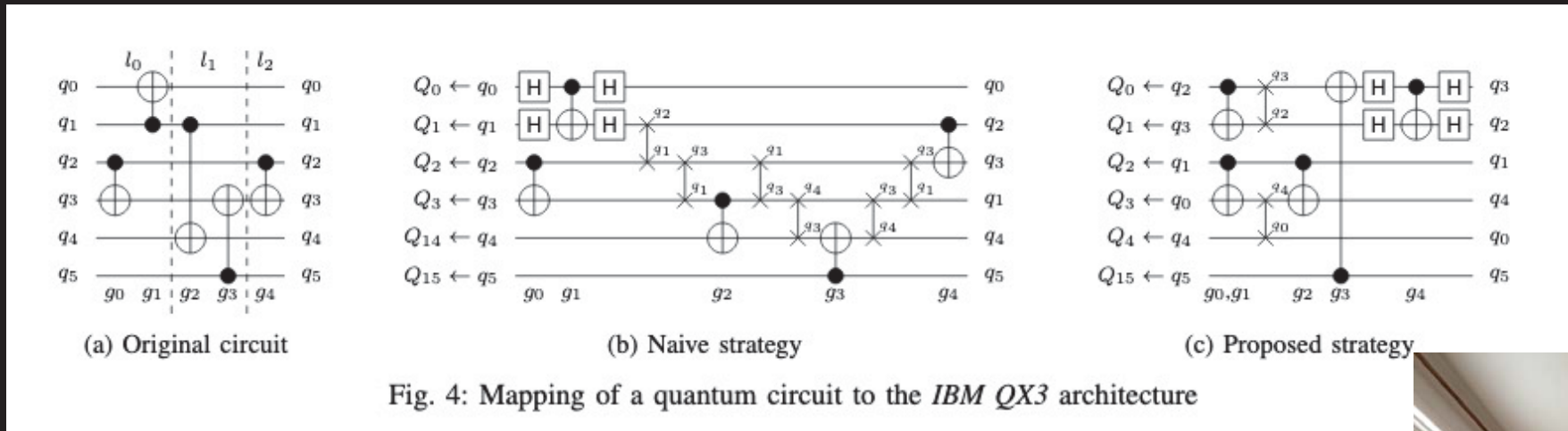
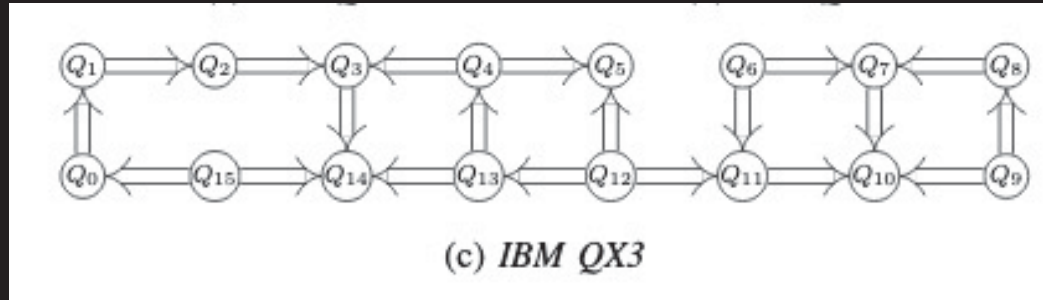

Quantum volume

Many factors contribute to the performance of the overall system

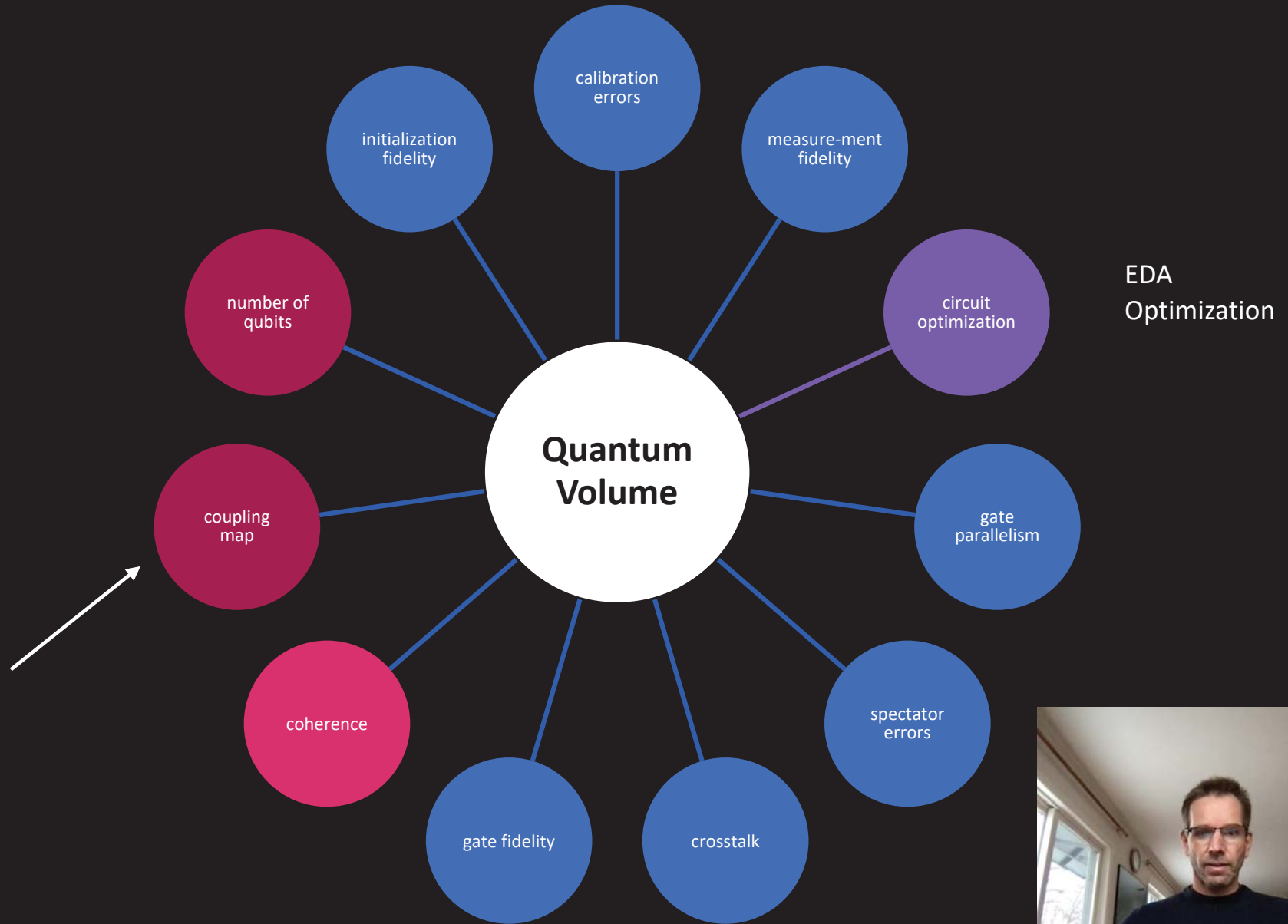
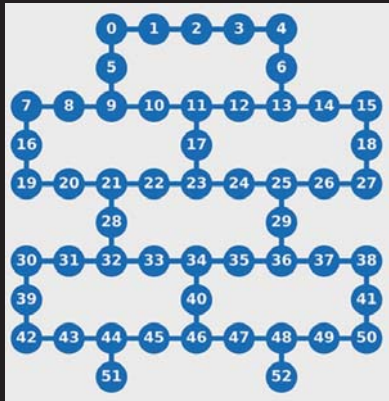

Quantum Volume 64: How did we do it?

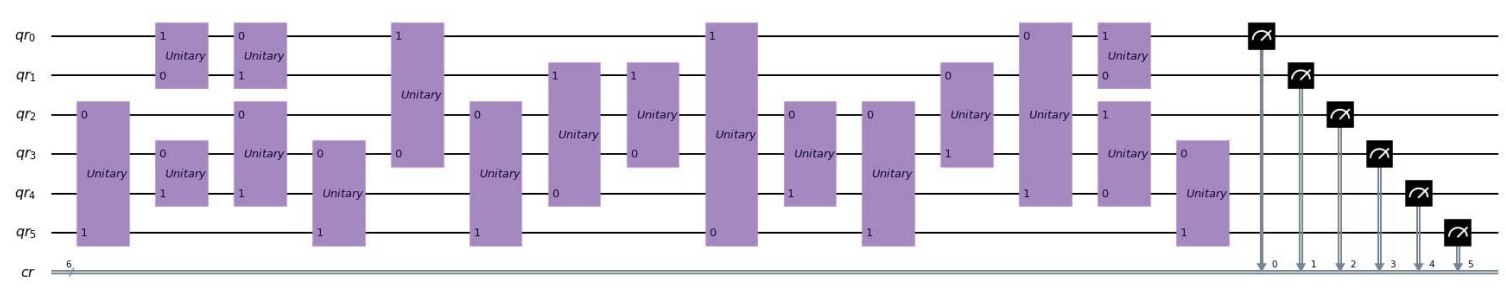

Jurevic et al.,
arxiv:2008.08571

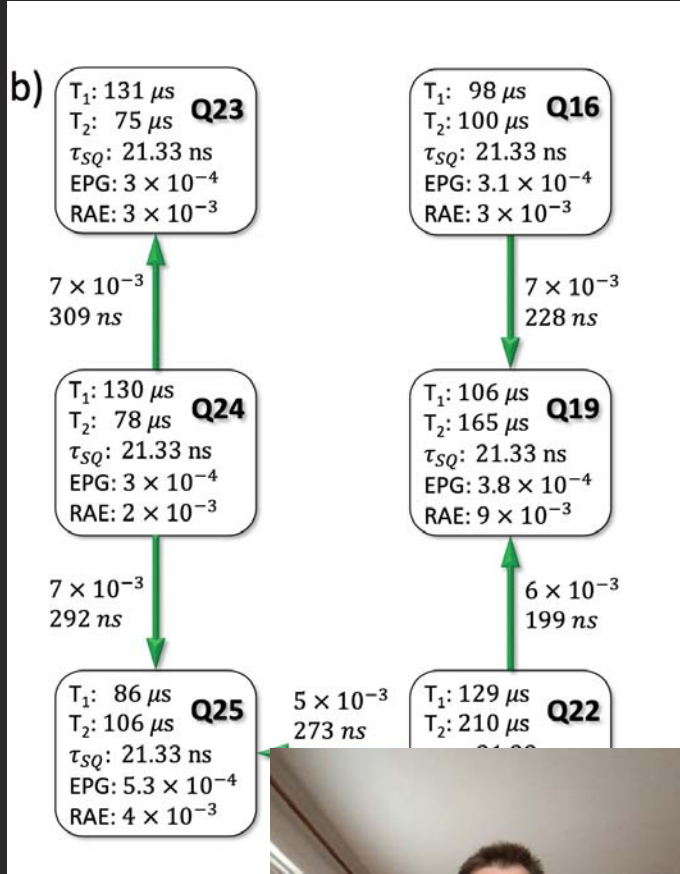
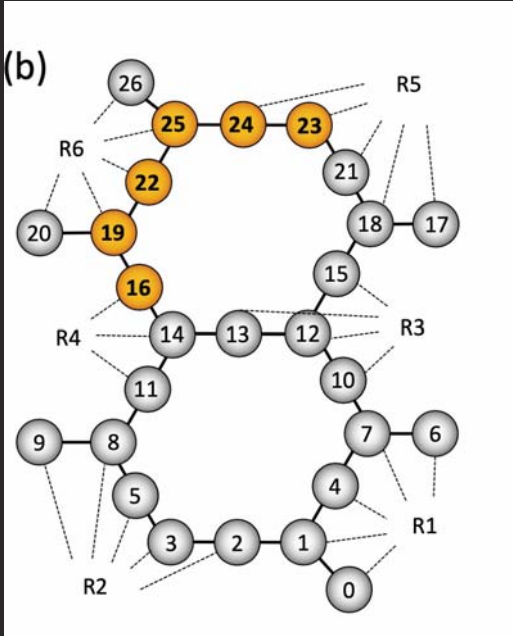

Quantum Volume 64: BIP Compiler & SU(4) Pulse Decomposition

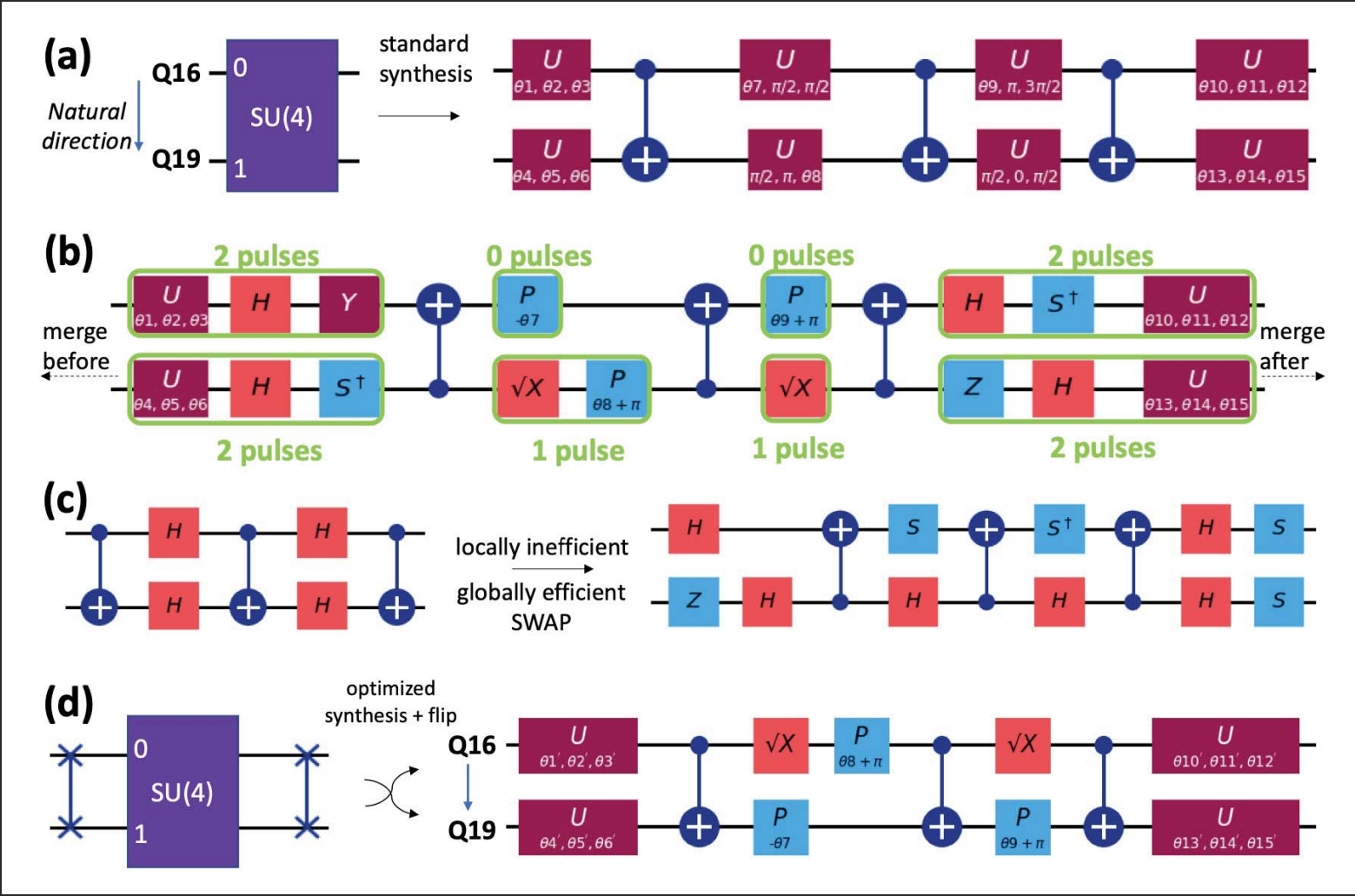

Quantum Volume 64: BIP Compiler & SU(4) Pulse Decomposition

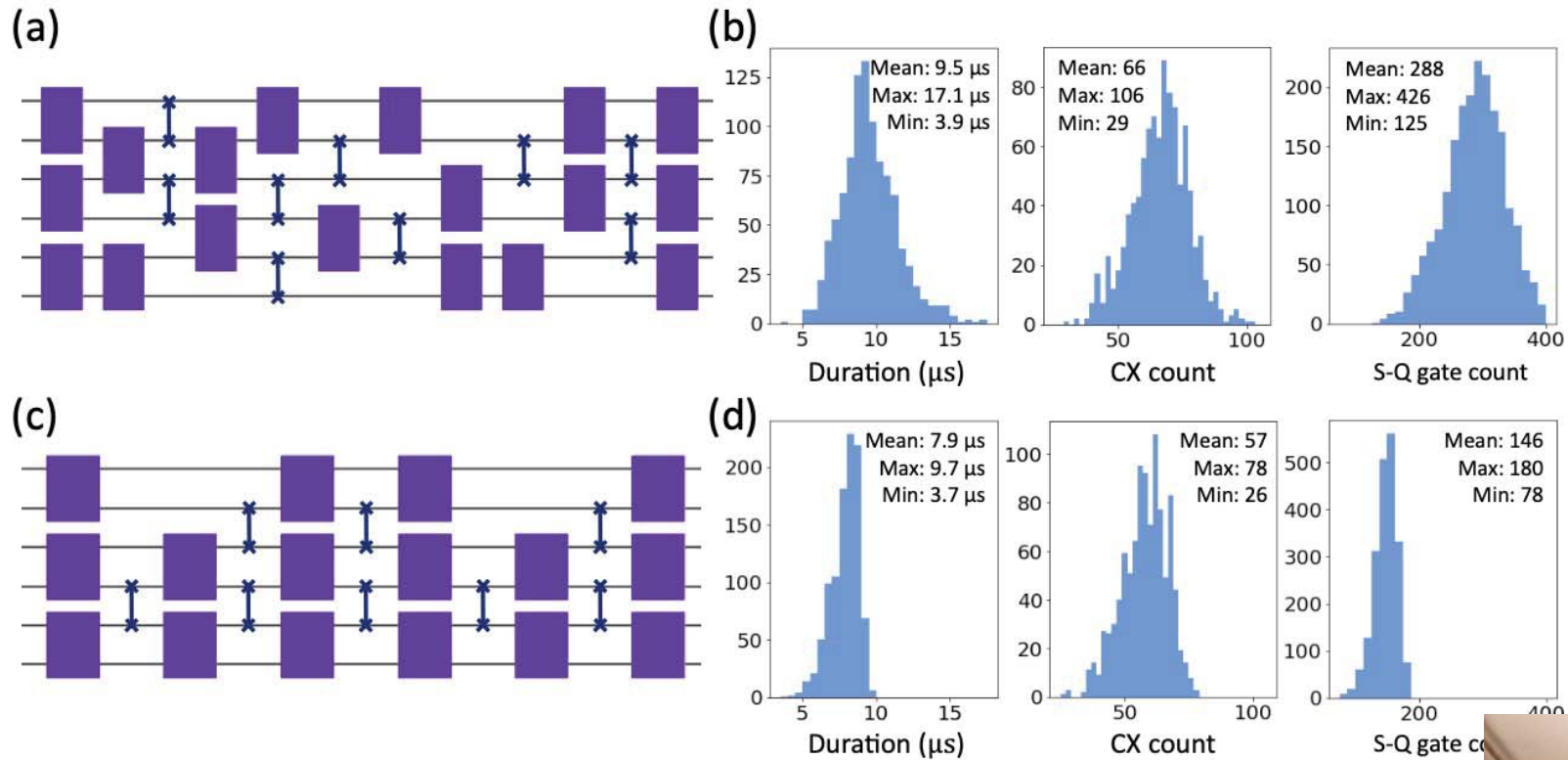

Development Roadmap

2019 2020 2021 2022 2023 2024 2025 2026+



Enterprise Clients	Use case exploration Problem mapping Skills building				Workflow integration Application development Skills building			
Model developers	Qiskit application modules				Quantum model services			
Algorithm developers	Natural Sciences		Finance		Natural Sciences		Finance	
	Optimization		Machine Learning		Optimization		Machine Learning	
Kernel developers	Circuits		Qiskit Runtime	Dynamic circuits	Prebuilt quantum runtimes		Prebuilt quantum + HPC runtimes	
Quantum systems	Falcon 27 qubits	Hummingbird 65 qubits	Eagle 127 qubits	Osprey 433 qubits	Condor 1121 qubits	Beyond 1K - 1M+ qubits		
IBM Cloud	Circuits		Programs		Models			



Components of an IBM Q System

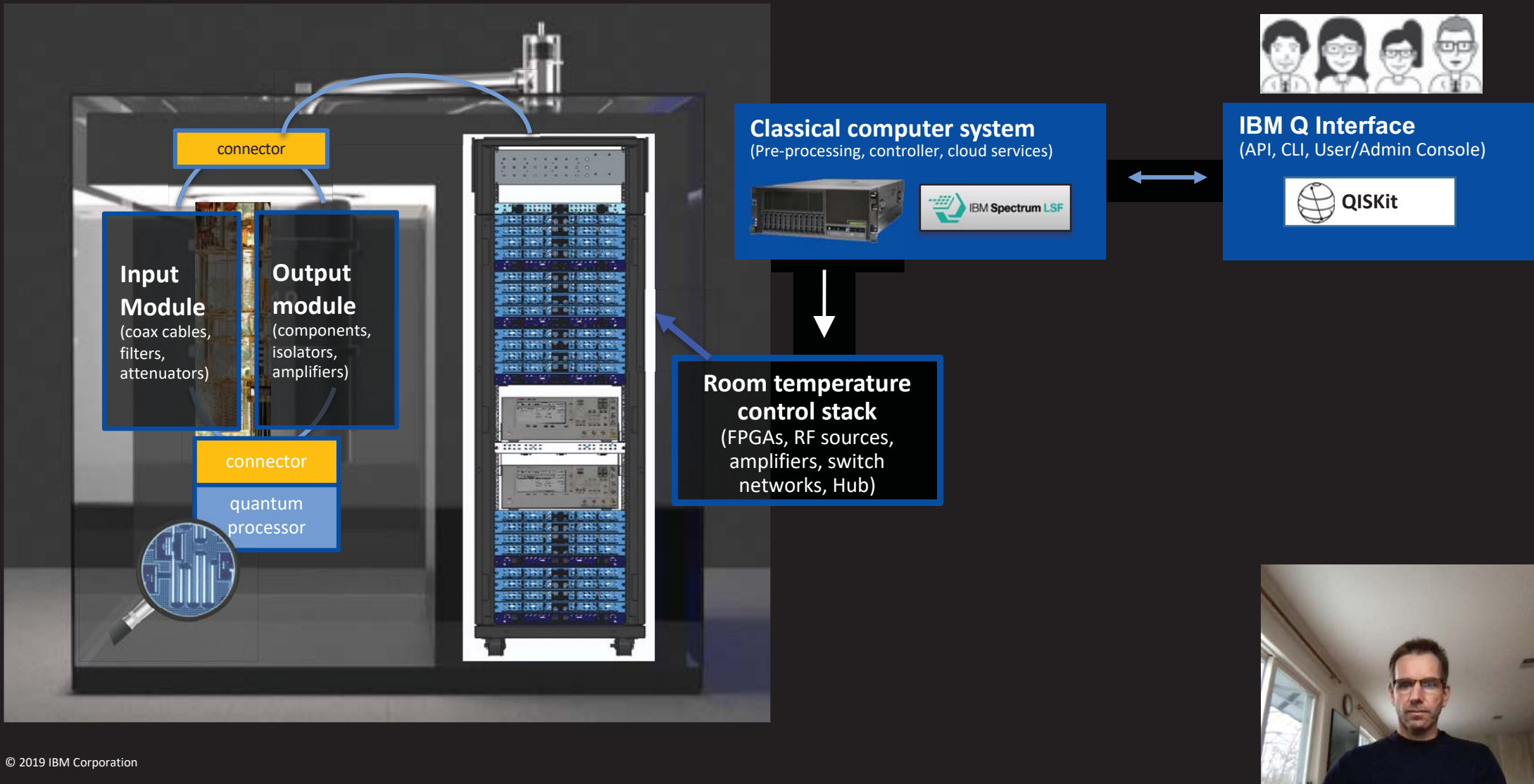

Qiskit Runtime



Quantum programs use nested loops that run back and forth across the cloud

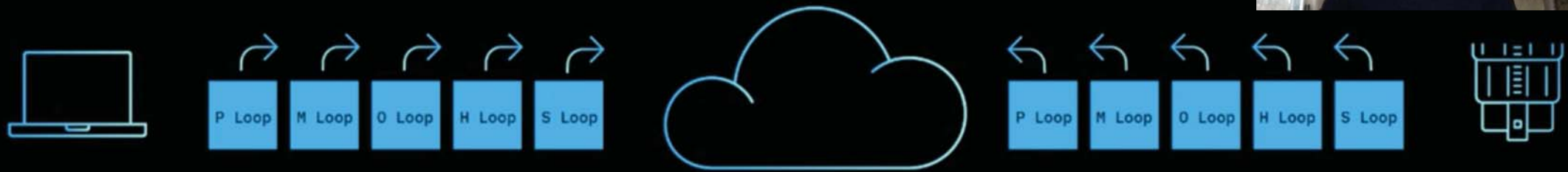

Qiskit Runtime will increase performance up to 100X using hybrid cloud technology on the IBM Cloud

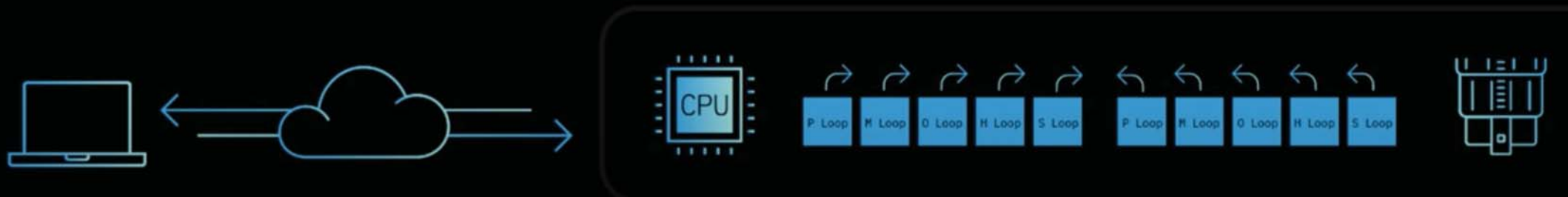

Dynamic circuit

A static circuit is run sequentially with the result returned to the user.



A dynamic circuit can measure qubits mid-circuit and change the flow of processing.



Development Roadmap

Mid-circuit measurements and resets

Resetting multiple times -> greater fidelity of zero state preparation

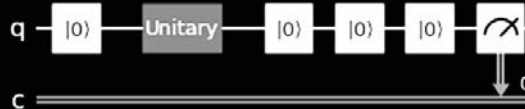
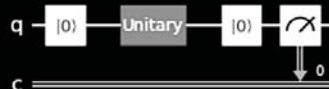

Reset error distribution over Haar random 1Q initial states on Manhattan

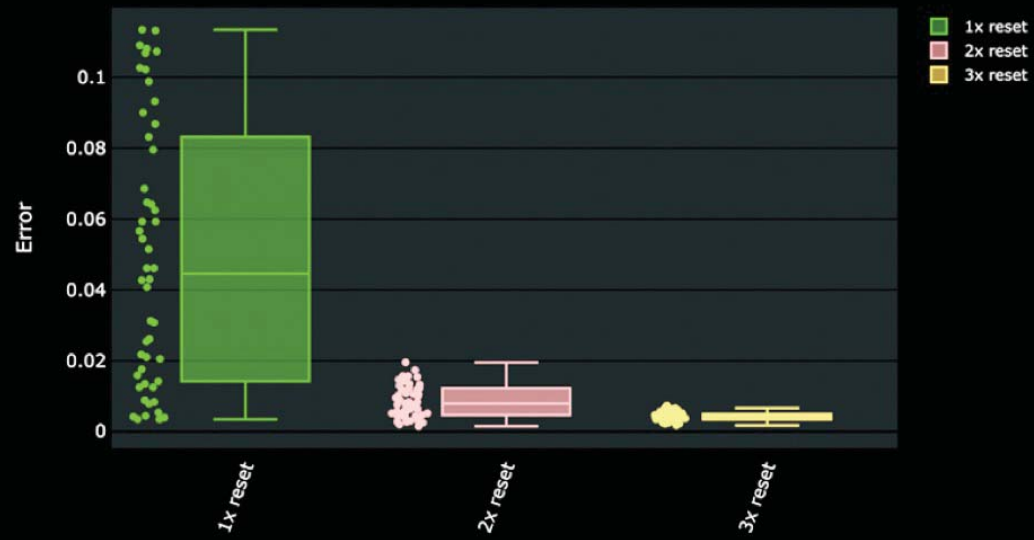

Model developers

Kernel developers

Quantum systems

IBM Cloud

Circuits

Programs

Applications

Phase estimation of a given unitary

Post-processing - each circuit measured only at end

```
for k=1, ..., m
```

```
  for s = 1, ..., floor(resources/(2*m)):
```



Dynamic Circuits – each measured multiple times

```
for s = 1, ..., floor(resources/m):
```

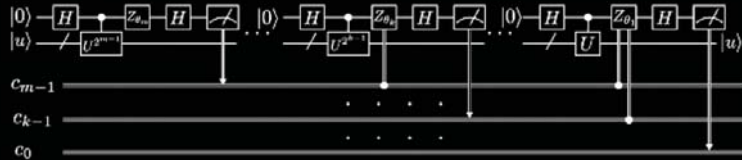

Dynamic circuits

- Win for limited resources

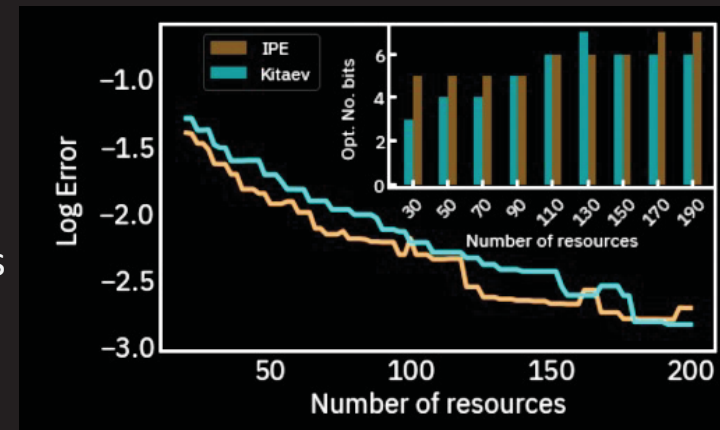

Model developers

Kernel developers

Quantum systems

IBM Cloud

Circuits

Programs

Applications

Development Roadmap

2019 2020 2021 2022 2023 2024 2025 2026+



Enterprise Clients	Use case exploration Problem mapping Skills building				Workflow integration Application development Skills building			
Model developers	Qiskit application modules				Quantum model services			
Algorithm developers	Natural Sciences		Finance		Natural Sciences		Finance	
	Optimization		Machine Learning		Optimization		Machine Learning	
Kernel developers	Circuits		Qiskit Runtime	Dynamic circuits	Prebuilt quantum runtimes		Prebuilt quantum + HPC runtimes	
Quantum systems	Falcon 27 qubits	Hummingbird 65 qubits	Eagle 127 qubits	Osprey 433 qubits	Condor 1121 qubits	Beyond 1K - 1M+ qubits		
IBM Cloud	Circuits		Programs		Models			



IBM Quantum Network: A Snapshot

Over 300,000 users have...

Run over 700 Billion quantum circuits

1.4 Billion quantum circuits per day

using total 34 quantum computers
deployed up to date

More than 140 Clients and Partners

Collaborating on 30+ applications

Over 300 contributors to Qiskit

Over 400 scientific papers so far



Thank you

Leon Stok

VP EDA

—
leonstok@us.ibm.com



